

ULTRAJET[®] 305HT

Advantages of UltraJet 305HT

- Weight dry 205 kg (452 lb.)
Weight wet 243 kg (534 lb.)
- 10% Higher static thrust than the standard UJ305. 3040 lb. of static thrust at 250hp
- Superior static thrust to wet weight ratio of any production waterjet currently available
- Developed specifically to provide increased static thrust for:

Bridge Erection and Towing purposes

- Uses same high quality production methods as the UJ305 to allow volume manufacture at competitive prices
- Superior manoeuvrability. Ability to accelerate quickly, reverse, stop, rotate, hold station and move sideways
- Light weight and compact design with a variety of on jet and remote mounted hydraulic control systems
- Installation dimensions enable exchange with standard UJ305 with minimal modifications

UJ305 HIGH THRUST

The **ULTRAJET 305 HIGH THRUST (HT)** is a derivative of the UltraJet 305 which has been in service world-wide for 10 years. The UJ305HT has the same major installation dimensions and can be installed into an identical space envelope. Incorporating an efficient and robust axial flow pump, reverse and steering controls, it has many of the same design features as used in the current "UltraJet range".

The proven 4 bladed design is less susceptible to mechanical damage than multi bladed designs.

To achieve superior thrust, design improvements have been made to the intake and impeller of the UJ305HT.

This high thrust unit was specifically introduced into the UltraJet range for Bridge Erection and Towing applications where high static thrust is a prerequisite.

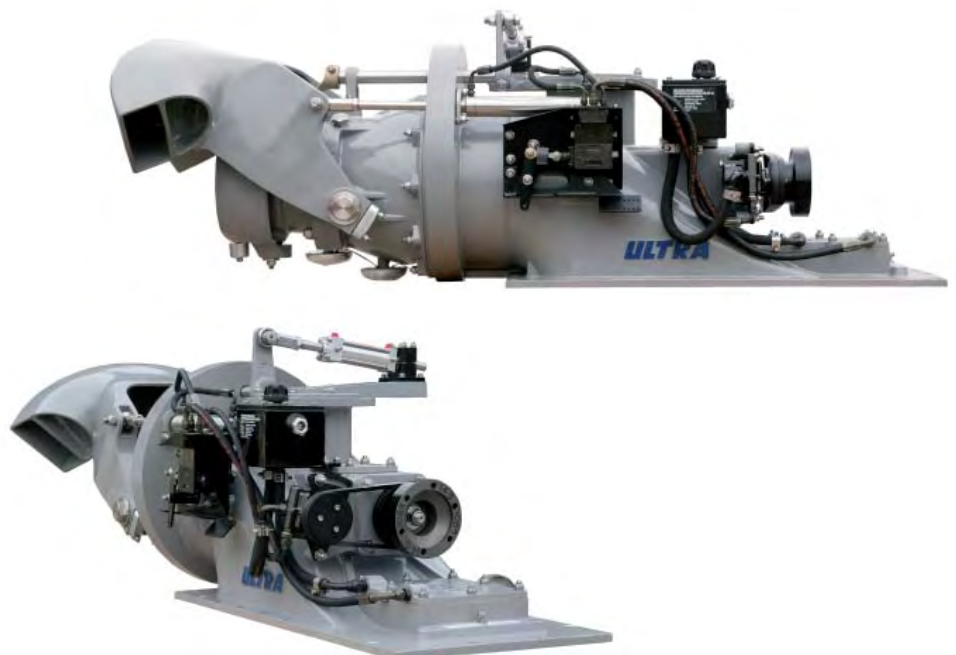

Lloyds ISO9001 Approved

UltraJet 305HT Dynamic Thrust & Installation Data

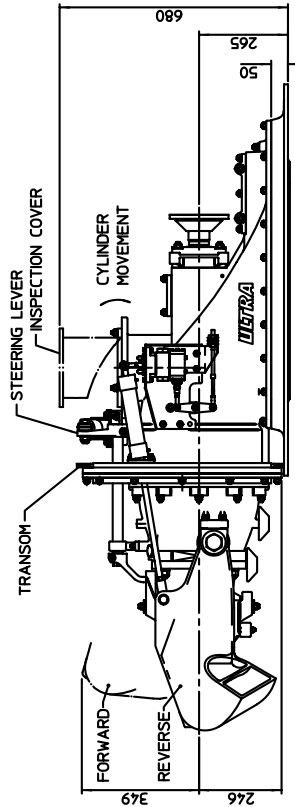
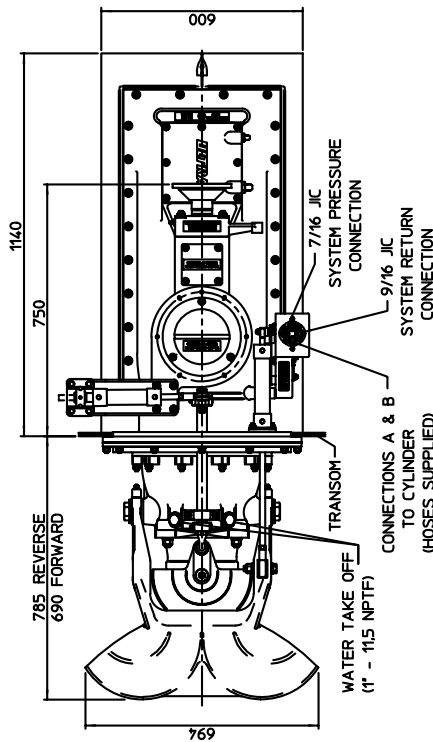
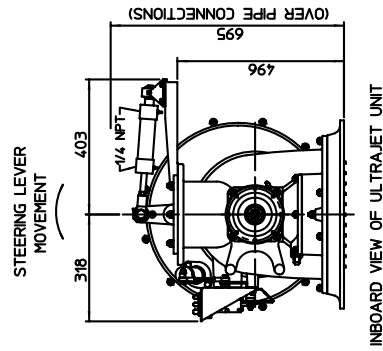
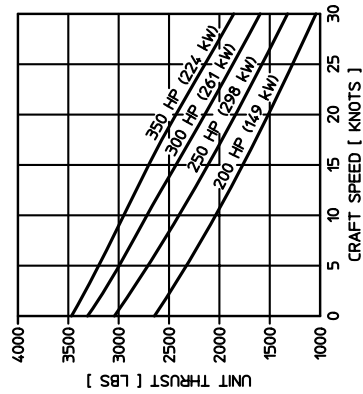

ULTRAJET 305HT

Base jet without controls
 Weight dry 205 kg (452 lb.)
 Weight wet 243 kg (534 lb.)

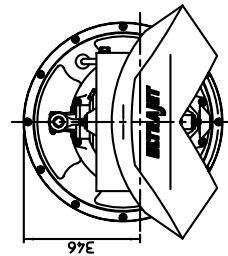

Ultra Dynamics Limited

Upperfield Road,
 Kingsditch Trading Estate
 Cheltenham, Glos, GL51 9NY, England.
 Tel: +44(0) 1242 707900 Fax: +44(0) 1242 707901
 E-mail sales@ultradynamics.demon.co.uk

www.ultradynamics.com

Ultra Dynamics Marine, LLC

1110A Claycraft Road
 Columbus, Ohio 43230, U.S.A.
 Tel: (614) 759 9000
 Fax: (614) 759 9046
 E-mail sales@ultradynamics.com

We have a policy of continuous improvement in design. Specifications may, therefore, be changed without notice.
 When considering applications for this equipment it is recommended that our Technical Sales Department is consulted.
 UD224/6/DTP/11/08 © Ultra Dynamics Ltd Printed in England